

CONDENSATE PUMP PCP230

with Audible 80db Alarm

Your condensate pump is designed as an automatic condensate removal pump for water dripping off an air conditioner evaporative coil. The pump is controlled by a float/switch mechanism which turns the pump on.

The unit you have purchased is of the highest quality workmanship and material. It has been engineered to give you long and reliable service.

READ INSTRUCTIONS CAREFULLY BEFORE ATTEMPTING TO INSTALL, OPERATE OR SERVICE THE PUMP. KNOW THE PUMP APPLICATION, LIMITATIONS AND POTENTIAL HAZARDS. PROTECT YOURSELF AND OTHERS BY OBSERVING ALL SAFETY INFORMATION. FAILURE TO COMPLY WITH INSTRUCTIONS COULD RESULT IN PERSONAL INJURY AND/OR PROPERTY DAMAGE! RETAIN INSTRUCTIONS FOR FUTURE REFERENCE. INSTALLATION AND CONNECTIONS ARE TO BE MADE BY A QUALIFIED PERSON.

CAUTION This Pump Has Been Evaluated for Use with water Only.

SAFETY GUIDELINES



DO NOT USE TO PUMP FLAMMABLE OR EXPLOSIVE FLUIDS SUCH AS GASOLINE, FUEL OIL, KEROSENE, ETC. DO NOT USE IN EXPLOSIVE ATMOSPHERES. PUMP SHOULD BE USED WITH LIQUIDS COMPATIBLE WITH PUMP COMPONENT MATERIALS.

DO NOT HANDLE PUMP WITH WET HANDS OR WHEN STANDING ON A WET OR DAMP SURFACE, OR IN WATER. THIS PUMP IS SUPPLIED WITH A GROUNDING CONDUCTOR AND/OR GROUNDING TYPE ATTACHMENT PLUG. TO REDUCE THE RISK OF ELECTRICAL SHOCK, BE CERTAIN THAT IT IS CONNECTED TO A PROPERLY GROUNDED GROUNDING TYPE RECEPTACLE.

IN ANY INSTALLATIONS WHERE PROPERTY DAMAGE AND/OR PERSONAL INJURY MIGHT RESULT FROM AN INOPERATIVE OR LEAKING PUMP DUE TO POWER OUTAGES, DISCHARGE

LINE BLOCKAGE, OR ANY OTHER REASON, A BACKUP SYSTEM(S) AND/OR ALARM SHOULD BE USED. SUPPORT PUMP AND PIPING WHEN ASSEMBLING AND WHEN INSTALLED. FAILURE TO DO SO MAY CAUSE PIPING TO BREAK, PUMP TO FAIL, MOTOR BEARING FAILURES, ETC.

INSTALLATION

1. Before installing pump, allow air conditioner to cycle several times, collecting condensate in a separate container to help flush any residual oils that may remain in the system.
2. Carefully unpack the pump. Remove the card board insert from the motor cover air slot. Carefully slide the insert away from the pump. This insert is used to prevent switch movement during shipment.
3. Mounting the pump: provided to mount the unit, the tank has two removable metal hanging tabs spaced 11½" apart. The unit should be mounted either on the side of the air conditioner unit or nearby wall. The unit also has 4 vibration absorbing rubber feet for placing pump on the floor. Pump must be level and the inlet must be below the coil drain. Conduit fittings are not compatible with the plastic pump housing.
4. The pump should not be installed in a manner that will subject it to splashing or spraying.
5. This pump is not intended for use inside air plenums.

Flow rate capacity (GPH):						
1ft	5ft	10ft	15ft	20ft	22ft	24ft
96	83	64	42	13	2	0

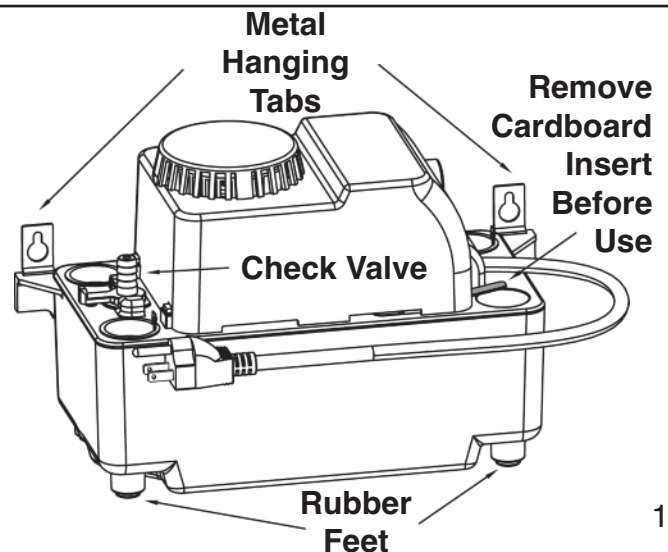

ELECTRICAL CONNECTIONS



1. Shut off electrical power at fuse box before making any connections. All wiring must comply with local codes.
2. Line voltage: Connect power cord to line voltage specified on motor and nameplate. Power cord must be connected to a constant source of power (not a fan or other device that runs intermittently).
3. Safety switch: **CAUTION!** The safety overflow switch should be connected to a class II low voltage circuit. To control a thermostatic circuit the COM and NO connections from the safety switch are to be wired in series with the low voltage thermostat circuit to shut down the heating/AC circuit.
4. 230VAC, 50/60Hz, 0.8A, 1/10hp at 20' lift operation thermal-protected motor includes 6ft cord.

PIPING

1. Run flexible tubing or pipe from evaporator drain into one of the three pump inlets. Be sure inlet piping is sloped downward to allow gravity flow. Extend the inlet piping into the tank from 1 to 3" to ensure that it will not interfere with proper float operation. Be sure that the inlet piping is cut at an angle where it enters the tank.
2. The outlet piping should be flexible tubing secured with a hose clamp (not provided) or pipe (3/8 inch I.D. maximum to prevent excessive flow back to unit). From condensate unit, extend discharge piping straight up as high as necessary. Do not extend this line above the maximum head/GPH (see chart on page 1 or 3). From this high point, slope discharge line down slightly to a point above drain area; then turn down and extend to a point below or approximately level with the bottom of the condensate unit. This will give a siphoning effect which will improve efficiency of the condensate unit and will, in most cases, eliminate the need for a check valve. (A rubber ball check valve is included with the pump). If it is not possible to slope discharge line down, make an inverted "U" trap directly above the pump at the highest point.

SERVICE INSTRUCTIONS

1. Make certain that the unit is disconnected from the power source before attempting to service or remove any component!
2. Be sure the floats move freely. Clean as necessary
3. Clean the tank with warm water and mild soap.
4. Check the inlet and outlet piping. Clean as necessary. Be sure there are no kinks in the line that would inhibit flow.

TESTING

1. Turn on power.
2. Remove motor/tank cover assembly and hold level.
3. Test motor switch by raising motor switch float with finger. Motor should turn on just before float contacts cover.
4. Test safety switch by raising safety switch float with finger. Safety switch should activate before float contacts cover.
5. Replace motor/tank cover assembly on tank. This pump is suitable for gas furnace condensate applications. Caution must be taken to ensure acidity of condensate does not increase below the average pH of 3.4 (to prevent localized pocket of acid that acts like a battery causing pitting) by routinely cleaning or flushing tank with fresh water.

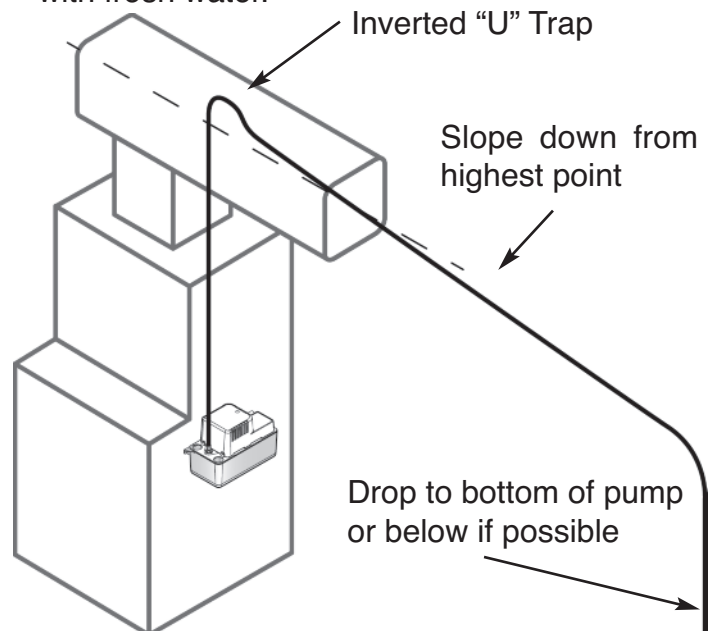

WIRING DIAGRAM

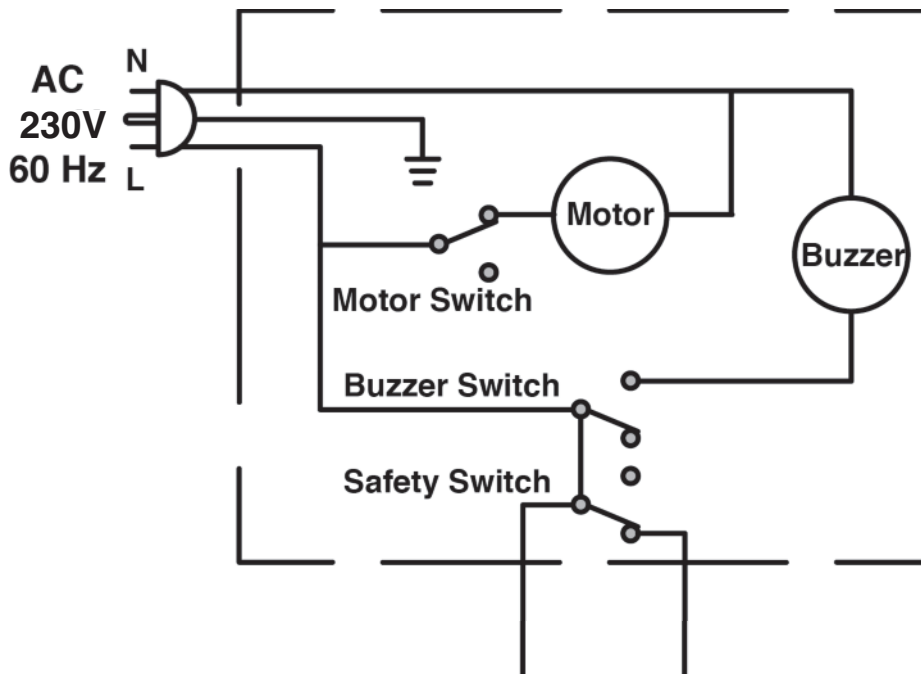

CHECK VALVE

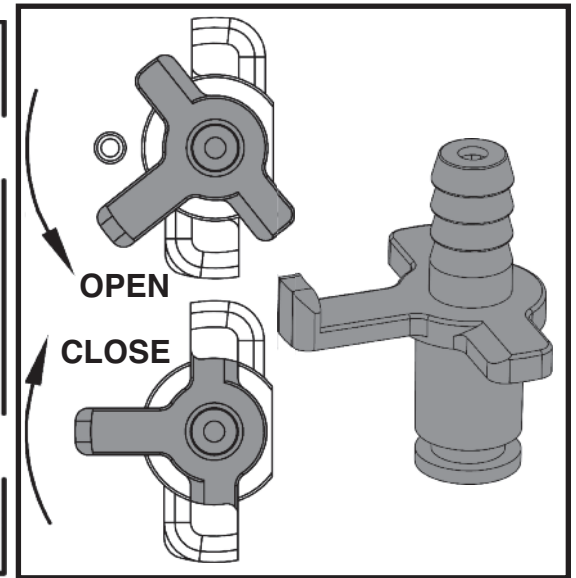

FEATURES

1. Independent safety switch & motor switch. Two wires come from the safety switch, in NC position. The switch will open when 2³/₄" water collects in the tank, to shut down the air-conditioner preventing over flow.
2. Independent audible alarm switch. Switch is Normally Open (NO). Buzzer switch will close when 2³/₄" water collects in tank, to activate the audible alarm. The 80 decibel alarm functions together with the safety switch .
3. ¼ turn Open/Close rubber ball check-valve.
4. Vibration absorbing rubber feet.
5. Metal side mount tabs, 11½" on center distance between tabs.
6. Specially designed leak-free motor & safety floater.
7. 1/2 gallon water tank.
8. 230 VAC, 60Hz, 0.8A, 1/10hp at 20ft lift operation thermal-protected motor.
9. Includes 6' power cord.

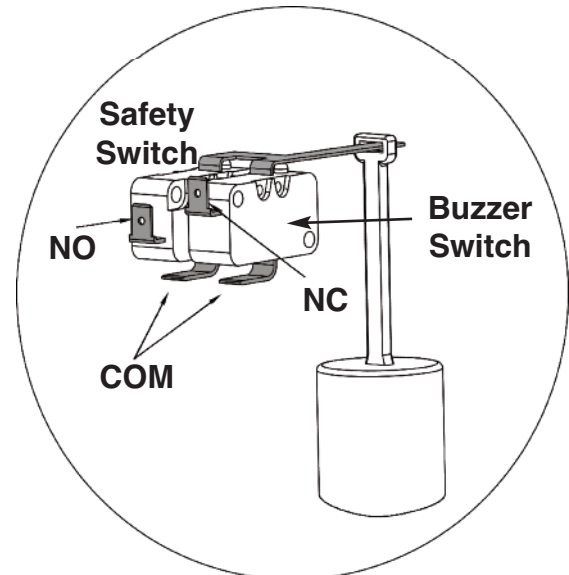

OPERATION

1. Pump motor activated when more than 2¼" water collects in the tank.
2. Pump motor off: when less than 1¼" water collects in the tank.
3. Pump alarm on/safety switch open: when more than 2¾" water has collected in the tank.
4. Each pumping cycle drives 1/4 gallon of water out of the tank.

Flow rate capacity (GPH):

1ft	5ft	10ft	15ft	20ft	22ft	24ft
96	83	64	42	13	2	0