

1. Application

Air Conditioner Type	Natural Cooling
Refrigerant Type	R22
Maximal Refrigerant Charged	4.85 kg / 10.69 lbs, not to exceed 5.0 kg / 11.02 lbs
Power Source	1 Phase 60Hz-208/230V
Safety Approval	UL

2. Specification

Compressor Type	Hermetic Scroll Compressor
Displacement	4.08in ³ /rev.
Oil Charged	47.3 fl oz
Weight (Oil Included)	86 lbs

3. Motor Specification

Motor Type	1-PH Induction Motor (PSC)
Pole Numbers	2 Poles
Insulation Grade	E Grade
Coil Resistance (at 25°C / 77°F)	Ω C-S 1.172, Ω C-R 0.331
Locked Rotor Amps	155 A
Running Capacitor	50μF-440V

4. Rated Performance Parameters

Rated Capacity	W 14,500 ±5%, BTU/hr 49,474 reference
Rated Input Power	W 4,450, W 4,550, ±5%
Rated Input Current	A 22.00, A 21.60, ±5%
NOISE	dB(A) 63 MAX
VIBRATION	overall level below 60 µm, peripheral areas below 70 µm

Rating Condition

Power Source	1 PH 60Hz-208/230V
Cond. Temp.	54.4°C / 130°F
Evap. Temp.	7.2°C / 45°F
Return / Suction Gas Temp.	18.3°C / 65°F
Liquid Temp.	46.1°C / 115°F
Ambient Temp.	35°C / 95°F
Discharge Tube Temp.	130°C / 266°F Max

5. Wiring Diagram

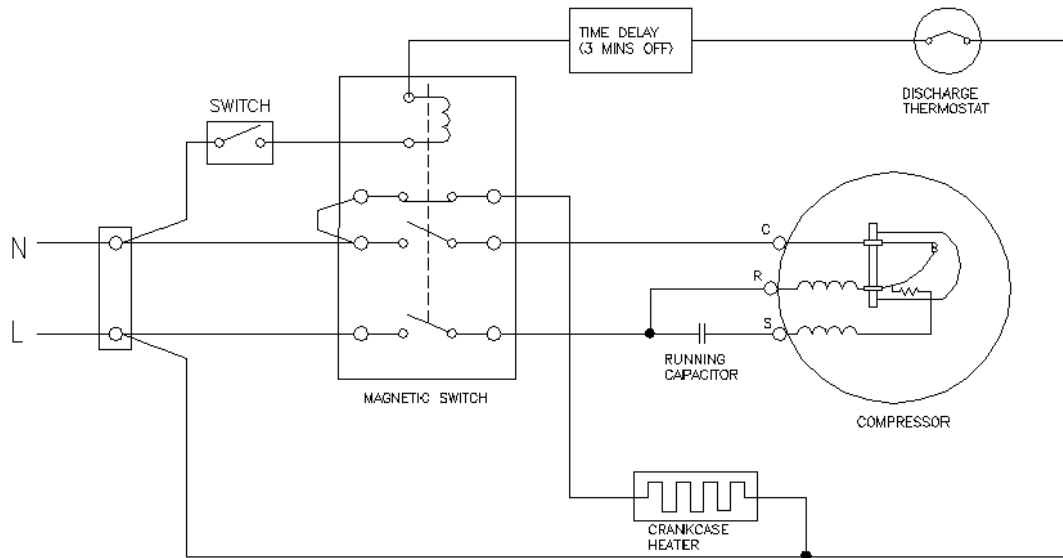

Part Code
E-0916-DSB
Name
Wiring Diagram

6. Other Application Notice

1. When designing the connection tube, the installer should consider the vibration stress at the compressor's start and stop to ensure it doesn't get damaged.
2. Do not put a compressor on its side or turn it over. It must always remain standing upright.
3. Please install the compressor right after removing the plugs.
4. When the amount of refrigerant charged in the air conditioner is over the max amount allowable, compressor specification should be discussed. (Install additional accumulator, oil heater, etc.)
5. Refrigerant must always be filled from the high side of the refrigeration system.
6. Avoiding compressor running in reverse by connecting electrical wires correctly.
7. Do not allow electric cables or the like to touch compressor directly.
8. To avoid water droplets and dust into the compressor, moisture-proof or dust-proof measures must be taken.
9. For split type air conditioners, the maximum piping length should be 49.21 feet, and elevation difference should be within 16.4 feet.
10. Wear safety goggles when servicing the unit.

Panasonic Scroll Compressor

Part No: SBR145H16A

No.	Part Code	Qty	Name
1	C-SBR145H16A	1	Compressor
2	A-0101-DSB	1	Terminal Box Cover
3	A-0201-DSB	1	Terminal Box Clip
4	A-0301-DSB	1	Eyelet Rub Lead Wire
5		1	Nameplate
6	B-0101-DSB	1	Screw Special

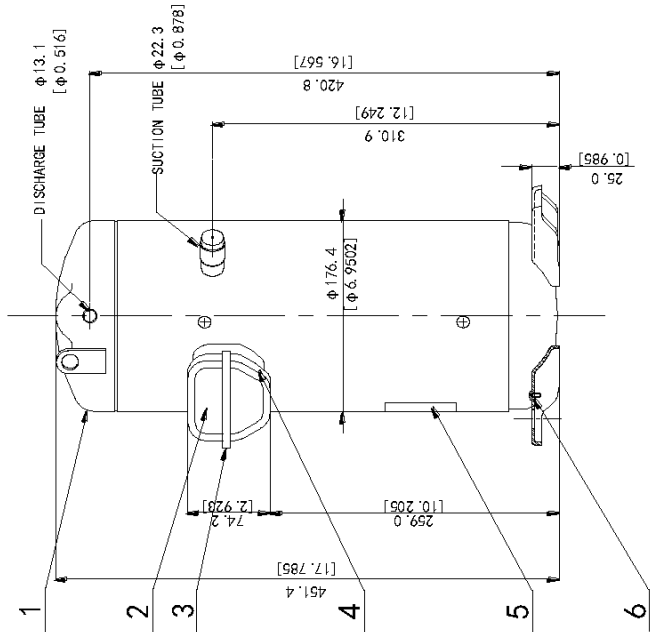
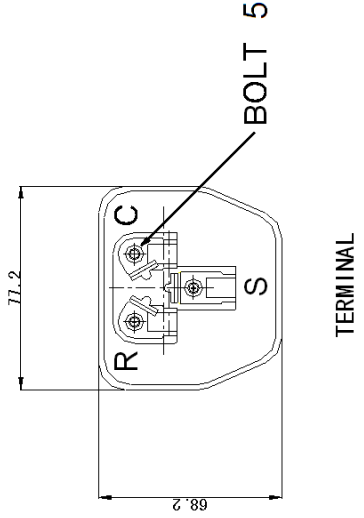
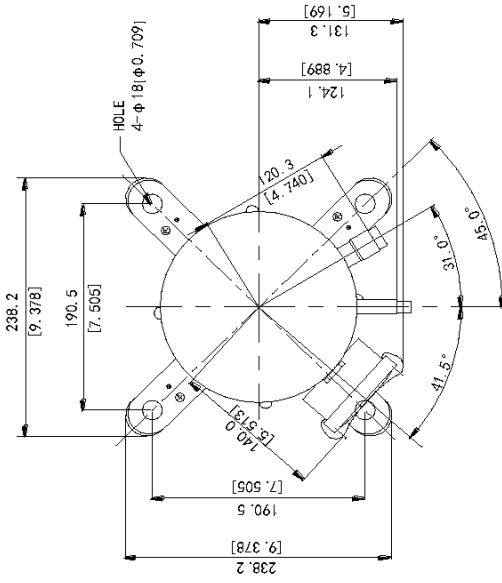

Part Code
D-0109-DSB
Name
Compressor Outline Drawing